

Pseudo Noun Incorporation in Niuean

Author(s): Diane Massam

Source: *Natural Language & Linguistic Theory*, Vol. 19, No. 1 (Feb., 2001), pp. 153-197

Published by: Springer

Stable URL: <http://www.jstor.org/stable/4047915>

Accessed: 11-04-2016 16:56 UTC

Your use of the JSTOR archive indicates your acceptance of the Terms & Conditions of Use, available at

<http://about.jstor.org/terms>

JSTOR is a not-for-profit service that helps scholars, researchers, and students discover, use, and build upon a wide range of content in a trusted digital archive. We use information technology and tools to increase productivity and facilitate new forms of scholarship. For more information about JSTOR, please contact support@jstor.org.



Springer is collaborating with JSTOR to digitize, preserve and extend access to *Natural Language & Linguistic Theory*

PSEUDO NOUN INCORPORATION IN NIUEAN *

ABSTRACT. This paper examines a phenomenon of Niuean (Oceanic) often called Noun Incorporation (NI). It is shown that, since the nominal element in these constructions is a phrase (NP) rather than a head (N^0), this phenomenon does not in fact constitute NI in the normal sense of the term. Instead, it is termed PSEUDO NOUN INCORPORATION, or PNI. An analysis is presented in which an object NP (rather than DP) is generated adjacent to a verb. Since NP cannot check absolutive case, it fails to move out of VP, hence it undergoes predicate fronting along with the verb to derive the ‘incorporated’ order V-O-PARTICLES-S-X: the normal order is V-PARTICLES-S-O-X. The properties of three subtypes of PNI are examined in some detail: general PNI, existential PNI, and instrumental PNI, and the analysis is developed to account for their properties. General PNI involves the generation of an NP object, in which the referential position remains open, resulting in a habitual reading for the sentence. Instrumental PNI is similar, except it does not have the same aspectual consequences. In existential PNI, on the other hand, an existential verb (*fai* ‘have/be’, *muhu* ‘have plenty/be plentiful’) binds the position in NP, thus allowing the NP to be referential and to be modified by a relative clause. Existential PNI thus results from a hybrid V/DET category (such as *fai*) which simultaneously binds the open position in NP and acts as the head predicate of the sentence. We see that the properties of Niuean PNI do not fit into the various typologies of NI available in the literature, hence a novel analysis is required, such as the one proposed in this paper.

INTRODUCTION

This paper examines a construction which Seiter (1980) terms Noun Incorporation (NI) in Niuean, an Oceanic language of the Tongic subgroup (as classified in Lynch 1998; Pawley 1966, 1967). NI is usually understood to be a phenomenon whereby a noun bearing a semantic role canonically expressed as an internal argument or adjunct phrase instead forms a single V^0 morphological unit along with its verb. NI is of theoretical

* I am very grateful to Harry Manamana and Sifa Ioane for acting as consultants on the Niuean language data used in this paper. In addition, for insightful comments I would like to thank Susana Bejar, Sandra Chung, Carol Georgopoulos, Jila Ghomeshi, Alana Johns, Joan Maling, Miriam Myerhoff, Elizabeth Pearce, Yves Roberge, Carolyn Smallwood, Wolfgang Sperlich, and the anonymous *NLLT* reviewers. Any errors are my own. Earlier versions of this work were presented at AFLA V, University of Hawai‘i, and at University of Toronto Syntax Project meetings. Funding for this work was received from SSHRC #410-97-0493.



interest largely because it calls into question the traditional separation of morphology and syntax. In NI structures, a noun is morphologically below the level of the word, yet it can continue to have a syntactic presence in the sentence (Baker 1988). In this paper, I will argue that in fact Niuean does not exhibit NI, since in Niuean NI (henceforth PSEUDO NOUN INCORPORATION, or PNI) the noun is actually a noun phrase, and thus under traditional X-bar assumptions as well as, under more recent formal definitions (e.g., Jackendoff 1977; Lightfoot 1979; Kayne 1994), it cannot be morphologically merged with the verb under V^0 .

In addition to the above formal understanding of NI, there is another broader and less technical use of the term, encompassing any instantiation of the tendency for an argument to develop a closer-than-usual relation with its verb under certain circumstances, such as when it lacks specificity. Often, such sentences display reduced transitivity (cf. Hopper and Thompson 1980; Georgopoulos 1998). What is usually called NI in Niuean is indeed part of this general tendency, since it involves a breaking down of the predicate-argument distinction; a distinction which in non-PNI sentences is encoded by transitive (Erg/Abs) case marking and by the presence of extended nominal projections (Grimshaw 1991) on the object NP, such as DP or KP. In this paper a distinction is made between NI, wherein a nominal head is incorporated into a verbal head (whether via head movement, lexical compounding or base-generated X^0 adjunction), and PNI, which involves a less radical, partial detransitivization process. As well as re-examining the status of NI in Niuean, this paper discusses general issues of NI, such as referentiality and existentiality in an attempt to understand the phenomenon crosslinguistically.

After this introduction the paper is organized as follows. Section 1 presents background information about Niuean. In section 2, the basic facts of Niuean PNI are provided, followed by a sketch of the proposed analysis of the phenomenon. A detailed examination of the Niuean PNI facts follows in section 3, then in section 4 it is shown how the proposed analysis can account for these facts. Section 5 briefly reviews previous analyses of NI, showing why these analyses are not suitable for the Niuean data. The conclusion, section 6, consists of some general remarks about NI and PNI.

1. BACKGROUND DESCRIPTION OF NIUEAN

1.1. *The Clause*

Niuean is a VSOX language, with an ergative case system which marks common nouns and proper nouns/pronouns differently, as seen in (1). Note the sentence begins with a tense/aspect particle (which can be null). The verb may be followed by various adverbial particles (not shown in (1)). In (2) I provide the essentials of the Niuean case system, for reference.¹

- (1)a. Ne kai e Sione e tau talo aki e huki.
Pst eat Erg Sione Abs Pl taro with Abs fork
 Sione ate the taros with a fork.
- b. Ne tohitohi a Sione.
Pst writing Abs Sione
 Sione was writing.
- c. Ko e tele e Sione a Sefa.
Pres kick Erg Sione Abs Sefa.
 Sione is kicking Sefa. (S.73d:29)
- d. Ne kai he pusi ia e moa.
Pst eat Erg cat that Abs bird.
 That cat ate the chicken. (S.73a:29)

¹ Data is taken from a variety of sources as indicated following each example. Data not identified for source is taken from my own consultation notes. The abbreviations used in the example sentences are: L = Lane (1978), M = McEwen (1970), NAH = *Niue: A History* (Institute of Pacific Studies 1982), S = Seiter (1980), Sp = Sperlich (1997), TKL = *Tau Koloa Fakamotu ha Niue: Tau Koloa Laufa* (Cole and Kulatea 1996), W = Whittaker (1992). In addition, Rex et al. (n.d.) and Kaulima and Beaumont (1994) were of use. Where they were lacking, glosses have been added in this paper. In some cases, glosses have been changed for consistency. Orthography also has been changed in places. For example, McEwen uses *ng* for a velar nasal, whereas I follow standard Niuean orthography in using *g*. Abbreviations used are: Abs: absolutive, Art: article, AspAdv: aspectual adverb, Comp: complementizer, Comtv: comitative, Dem: demonstrative, Dir: directional, Emph: emphatic, Erg: ergative, Fut: future, Loc: locative, Man: manner, Neg: negative, Nfut: Non-future (embedded), Perf: perfect, Pl: plural, Pred: predicative marker, Pres: present, Prog: progressive, Prt: particle, Pst: past, Ques/Q: question, Sbjctv: subjunctive, Voc: vocative.

(2) *Niuean Case Marking*ERG ABS

Proper/Pronoun e a

Common he e

1.2. *The Nominal Phrase*

The Niuean Determiner Phrase (DP) consists of the elements in (3), which can vary in order as shown.² Examples appear in (4).

(3)a. Case Art [Noun ModifierP] PossessorP

b. Case PossessorP Art [Noun ModifierP]

(4)a. e tau [mena gahua] haau

Abs Pl thing work your

your tools

b. e [kapiniu] he kulī

Abs dish Gen dog

the dog's dish

(S:90a.34)

c. e haana a [tupuna fifine]

Abs his Art grandparent female

his grandmother

(S.119a.45)

A detailed study of the Niuean nominal phrase remains to be undertaken. For the purpose of this paper I assume that the noun and the following modifier phrase form a constituent (NP), as bracketed in (3) and (4), from which the prenominal markers and the genitive possessor phrase are excluded. Following recent research in nominal structure (e.g., Bittner and Hale 1996; Ritter 1992; Giorgi and Longobardi 1991; Pearce 1998) I consider that the NP is topped with the extended functional projections KP (K = Case) and ArtP (Art = Article).³

² Following usual terminology I refer to the maximal NP structure as DP in the text of this paper, though technically, in Niuean, KP would be a better term, since Case appears to be the highest extended nominal projection.

³ With respect to the genitive possessor phrase, it can be argued that the noun and modifier form an NP constituent which excludes this phrase, since the possessor can appear

2. NIUEAN PNI

2.1. *The basics of Niuean PNI*

An example of PNI appears in (5b). Note that in (5a) the order is V-Prts-Sbj-Obj (where here the particles are an adverb and an emphatic), while in (5b), the PNI sentence, the order is V-Obj-Prts-Sbj. Furthermore, the object in (5b) appears without the preceding functional elements found in (5a), the case, and number articles. Finally, the agent, which is ergative in (5a), is absolutive in (5b), thus indicating that the PNI sentence is intransitive.

- (5)a. Takafaga tūmau nī e ia e tau ika.
hunt always Emph Erg he Abs Pl fish
 He is always fishing. (S.183a:69)

- b. Takafaga ika tūmau nī a ia.
hunt fish always Emph Abs he
 He is always fishing. (S.184a:69)

In normal Niuean sentences, each nominal element is obligatorily preceded by a case marker (*e* in (5a)), and possibly by other grammatical morphemes, grouped together as articles, which indicate number and specificity (*tau* in (5a)). One diagnostic for PNI is thus the absence of pronominal functional elements. Sentences exhibiting PNI are those where the verb is directly followed by a nominal which has no preceding case marker. PNI sentences can be further diagnosed if there is an overt agent marked with absolutive case, rather than with ergative case, or if there are post-verbal adverbial particles (as *tūmau* in (5b)), which follow the PNI nominal. All the examples of PNI in this paper exhibit one or more of these diagnostics. We return below to further examination of the properties of PNI in Niuean.

Niuean PNI has been variously considered to be a lexical or a syntactic process. It is first discussed in detail by Seiter (1980), and several linguists have used the empirical observations made in his work. Seiter argues for a syntactic analysis within a Relational Grammar framework to account for the fact that an instrument can advance to object in a PNI sentence, but not,

either before or after the NP, as seen in (3) and (4). If we assume that genitives are external arguments, and if we rule out rightward movement (Kayne 1994), this means that in (4a) [N ModifierP] has moved to the left, and that it therefore must form a constituent. The nature of the position to which the NP moves remains unclear. The main point regarding NP structure in this paper is simply to show that it is plausible to consider that Niuean has an NP constituent.

he claims, in other intransitive sentences.⁴ Baker (1988) uses Niuean data to support a syntactic movement analysis of incorporation in Government and Binding theory, since Niuean NI appears to obey the ECP.⁵ On the other hand, Rosen (1989) presents Niuean as an example of lexical compounding, a view shared by di Sciullo and Williams (1987). Baker (1997) concedes that Oceanic languages should be analyzed as involving lexical incorporation, a position already hinted at in Baker (1988, p. 454, note 17), where he allows that V + N might be purely lexical in Niuean.

Having presented the core case of Niuean PNI in (5), we proceed in the next subsection to examine cases with more complex nominals.

2.2. Niuean PNI Involves NPs

Analyses of NI have been developed by various authors, such as Baker (1988, 1997), Van Geenhoven (1996), Ghomeshi and Massam (1994), Rosen (1989), Sadock (1980, 1985, 1991), Mithun (1984), Johns (1999), di Sciullo and Williams (1987). Essentially, for all of these authors, NI is an operation whereby a noun and a verb together form an X⁰ constituent, or a word. However, examination of Niuean PNI reveals that this is not the case in Niuean. It is for this reason that I claim that Niuean does not exhibit true NI. The evidence for this claim is seen in the examples below, where the putatively incorporated nominal appears in bold.⁶

- (6)a. Ne inu **kofe kono** a Mele.
Pst drink coffee bitter Abs Mele
 Mary drank bitter coffee.
- b. Ne holoholo **kapiniu kiva** fakaeneene a Sione.
Pst wash dish dirty carefully Abs Sione
 Sione washed dirty dishes carefully.

⁴ Massam (1998) modifies this claim to state, rather, that instruments can advance only if the verb assigns an agent thematic role. Once stated as a condition on thematic structure rather than syntactic structure, this fact no longer requires a syntactic account of NI. In the analysis provided in this paper, either situation could be handled.

⁵ Di Sciullo and Williams (1987) state that Baker must posit a preposition insertion rule in order to maintain a syntactic account, since middle case-marked objects (which have properties of direct and of indirect objects) as well as direct objects, are able to incorporate. Such a rule is not required if the generation of the middle case morphology is simply optional.

⁶ In this section I mingle two types of incorporation examples, namely general incorporation and existential incorporation. The arguments presented here hold equally of both types. In sections 3 and 4, the similarities and differences between the two types of incorporation predicates are discussed.

- c. Fai **hopo loa** foki ne ua nī e lau he mole.
Be skip long again Pst two Emph Abs leaf Comp pass
 There are also some long skips over two. (TKL: weaving instructions)
- d. Ne manatu e Mataginifale ko e mena fai
Pst think Abs Mataginifale Pred Abs thing have
mata-fohi haku hiapo a ia ne huhulu he
blade-scraper scratch tapa-plant Abs she Pst shove in
 malo felevehi ...
waist-cloth
 Mataginifale remembered that she had the blade of the tapa plant scraper which she had twisted in her waist cloth ...
 (NAH:ch. 1)
- e. Fai **tolili lolo** foki nī au ne toe.
have residue oil again Emph I Nfut left
 I have very little oil left. (Sp.321)
- f. Kua lata e pasikala ke fai **veli foou.**
Perf right Abs bicycle Sbjnctv have rim new
 The bicycle needs a new rim. (Sp.354)
- g. Fai **kalahimu tahataha** foki nī
be crab few again Emph
 There are few crabs. (Sp.90)
- h. Ne fai **fale lanu moana** a ia.
Pst have house colour blue Abs he
 He had a blue house.

Within a theory of phrase structure in which X^0 items cannot contain X' constituents, these constructions arguably do not display a V^0 containing a V and an N , since the nouns in question appear with modifiers.⁷ For

⁷ Seiter (1980) notes the possibility for modifiers to appear with incorporated nominals. Bauer (1997) notes this possibility for Māori. She also notes the theoretical problem raised by the fact that incorporated nominals appear inside verbal particles, but are phrasal in nature. Chung (1988) discusses sentences with incorporated NPs in Chamorro.

these examples, however, a NI analysis might be maintained, where a compound lexical N (e.g., ‘bitter coffee’) further compounds with a verb (e.g., ‘drink’) to form a compound verb, yielding $V_{[V+N]}$. This view would be consistent with Travis’s (1988) analysis of adjectives, where they are treated as X^0 elements which are adjoined to their nouns. This analysis, however, meets difficulties with examples such as those in (7), in which the putatively incorporated nominal is more complex, and can include within it grammatical morphemes such as *mo* ‘Comitative’, and *e* ‘Absolute’ in (7b), and *ke* ‘Subjunctive’ in (7c).

- (7)a. Kua leva lahi e amaamanaki ke fai pepa
Perf longtime very Abs look=forward=to Sbjnctv be book
 pehē nai kua tohia ke fakamau aki e tau puhala
like this Perf written Sbjnctv hold=fast with Abs Pl ways
 gahua lima he motu ha tautolu ko Niue ...
work hand Gen island Gen our Pred Niue

There has been a long time of waiting for there to be a book like this, which was written to retain the ways of handiwork of our island Niue ... (TKL: introduction)

- b. Ne kai sipi mo e ika mitaki a Sione
Pst eat chip Comtv Abs fish good Abs Sione.
 Sione ate good fish and chips.
- c. Liga ko e mena ha ia a ti tupu ai e manatu ha
likely Pred Abs thing that thus grow Loc Abs thought Gen
 lautolu ... ke kumi mena ke nonofo ai a
they Sbjnctv seek thing Sbjnctv settle there Abs
 lautolu.
they

It is likely that it was this that caused them to start thinking that they would seek a place to settle. (NAH:ch. 1)

- d. ... ke kumi motu ke nonofo ai.
Sbjnctv seek island Sbjnctv settle there
 ... to seek an island where they could settle. (NAH:ch. 1)

- e. Mena mukamuka lahi nī ke pehē mena nākai
Thing easy very Emph Sbjnctv be=like thing not
 iloa he motu nai e mahani taute poa ke he tau
know on island this Abs custom do offering to Pl
 atua-motu ke tuga e falu a atu motu.
god-island Sbjnctv like Abs some Abs group island

It is very clear that the presentation of sacrifices to various gods like on some other islands was virtually unknown on this island.

(NAH:ch. 3)

In (7a) the modifying phrase *pehē nai* ‘like this’ appears within the incorporated nominal. In (7b) a conjoined phrase, which includes a preposition and a case marker, is incorporated.⁸ In (7c) and (7d), the Niuean equivalent of an infinitival relative (a subjunctive relative) appears inside the incorporated element, thus the incorporated material includes a subjunctive complementizer. In the first instance of PNI in (7e) a reduced relative clause appears inside the incorporated element, which contains a preposition and a demonstrative, while in the second instance of PNI in (7e) we see a nominal including a prepositional phrase incorporated.⁹ I take the presence of grammatical morphemes to indicate grammatical structure, hence, from these examples, and others like them, I conclude that the so-called incorporated element in Niuean is phrasal, and not lexical. Furthermore, I conclude that it is not lexical in two senses of this term: it is not formed in the lexicon and it does not constitute a subphrasal element.¹⁰ This poses difficulties for an NI account of Niuean PNI, since NI is understood to result in a lexical head X^0 . In the following section, I present an analysis of PNI as a natural outcome of the base generation of an NP (vs. DP) object, combined with the fact that Niuean is a predicate fronting language.

⁸ It is possible to argue that *sipi mo e ika* ‘fish and chips’ is a lexical item since it is such a conventional and common item, but I assume here that the grammatical elements contained in it are indicative of a phrase. The appearance of the adjective *mitaki* here further indicates that the incorporated element is phrasal.

⁹ In some examples (such as the second incorporation in (7e)) it is difficult to tell how much material has actually been incorporated, since unless there is a postverbal particle or an overt subject, nothing marks the end of the incorporation domain. Even if we discount examples like this, however, enough examples remain where the domain is demarcated (e.g., 27b) to allow us to conclude with confidence that functional elements can appear within an incorporated phrase.

¹⁰ I emphasize this, since for some NI researchers [V N] complexes are lexical items formed in the lexicon (e.g., Rosen 1989), while for others, such as Ghomeshi and Massam (1994) and Van Geenhoven (1996) they are X^0 items (hence arguably lexical items) formed in the syntax via X^0 adjunction of N^0 to V^0 . See section 5.

2.3. *Niuean PNI is the Generation of a Bare NP Object*

My claim regarding Niuean PNI is as follows. Niuean PNI is not the result of lexical or syntactic incorporation of an N into a V. Rather, PNI arises through the base generation of an NP without functional extended projections, followed by normal predicate fronting, i.e., movement of [V NP] to IP-initial position. In this section I will explain this claim in detail.

At this point it is necessary to discuss some aspects of general Niuean syntax, such as clause structure and case. Working within the framework of Chomsky (1995)¹¹ and building on Massam's (to appear) analysis of Niuean word order, I assume that a transitive clause has the structure shown in (8), derived as follows. First, the verb merges with a DP object to form a VP. Then, prepositional arguments are optionally adjoined to the VP (not shown in (8)). Above this an Absolutive Phrase is generated (roughly equivalent to AgrOP as described for ergative languages as in Bobaljik 1993). The v^{\max} is generated above AbsP, with the agent DP in its specifier position checking ergative case *in situ* (Massam 1994; Woolford 1997; Ura 1998). The DP object will move to the specifier of AbsP to check the strong D feature associated with absolutive case, before the transitive v^{\max} level is merged. At the IP level, a strong predicate feature in INFL will attract the VP predicate (Massam and Smallwood 1997), resulting in the VSOX order characteristic of Niuean clauses. This analysis builds on the VSO verb or predicate fronting analysis of Emonds (1980), Sproat (1985) and others (as discussed in the introduction of Carnie and Guilfoyle to appear), which is compatible with Kayne's (1994) claim that all languages are underlyingly SVO.¹²

¹¹ Unlike Chomsky (1995), though, I assume the existence of a functional projection above VP which I term 'Absolutive Phrase'.

¹² Following Carnie (1995) and Legate (1997), I consider that there is obligatory predicate reconstruction, which allows the object trace to be c-commanded by its antecedent at LF.

(8) TRANSITIVE

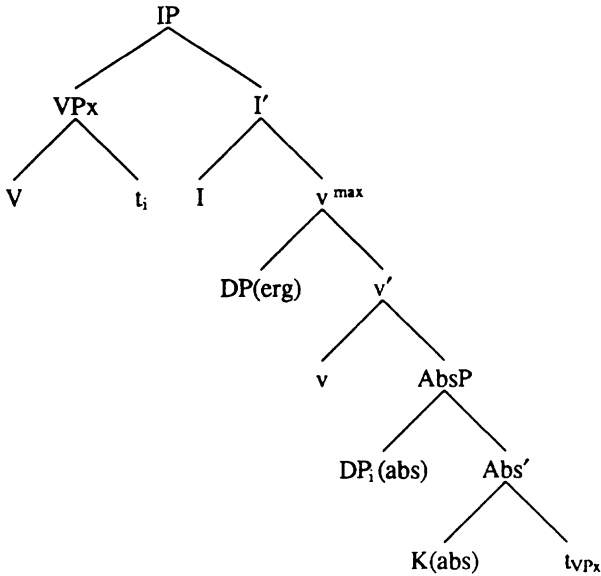

The Niuean intransitive clause is similar.¹³ Here, the verb merges with an argument, and prepositional arguments can be adjoined to the resulting VP. Above this, AbsP is merged, and the internal argument then moves to check the strong D feature associated with absolutive case in AbsP. At the IP level, once again, the VP predicate fronts.¹⁴

¹³ I ignore unergative verbs here, noting only that at the moment I consider them to be the same as unaccusatives (as Hale (1998) does for other Oceanic languages), contra Hale and Keyser (1993), although this area of Niuean syntax remains unexplored.

¹⁴ As discussed in Seiter (1980) the absolutive argument in (9) acts as a syntactic subject for Control, etc., as does the ergative argument in (8), hence the definition of subject for Control-like purposes in Niuean is 'highest argument' (see Massam 2000).

(9) INTRANSITIVE

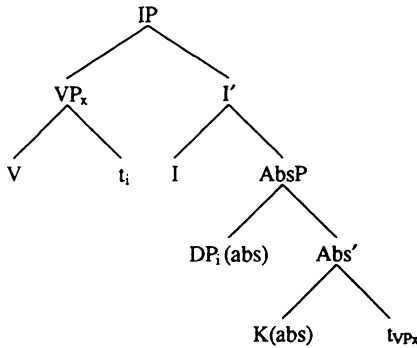

Let us now consider a PNI structure. Here, the verb merges with an argument which is not in this case a DP, but an NP. After AbsP is merged, the internal argument, which has no D feature and no case feature (since Case appears on an extended functional head, not on N), cannot check absolutive case. However, the agent DP argument can be merged with Abs, thus appearing in the specifier of AbsP, in which position it can check the strong D and case feature of AbsP.¹⁵ Now, when predicate fronting occurs, it is the VP_x dominating the V + NP which fronts to check the predicate feature on I.

¹⁵ Following the intuition of Biggs (1974) and Sperlich (1994) I assume that Niuean agents are external to VP. Further, I consider that agents can be variously generated in Spec of ErgP or Spec of AbsP. ErgP appears only in sentences where there is an agent, and where Abs has already been checked. This generalization for Niuean can be stated as: An argument is generated in v^{max} (hence ergative) only if (a) it is an agent and (b) absolutive case has been checked (Massam 1998). I assume here that a DP can check case in its base-generated position, providing it otherwise meets the criterion for checking domain (i.e., providing it is not sister to the verb).

(10) PSEUDO NOUN INCORPORATION

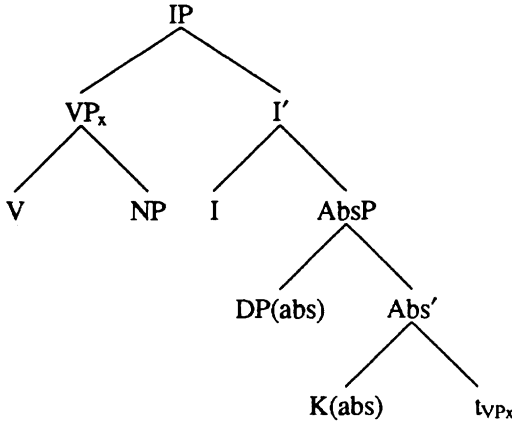

The claim here is that in PNI constructions, the VP, including the NP object, undergoes fronting to satisfy the 'predicate first' nature of Niuean. This accounts for the VOS order of PNI. Note that it is a maximal projection which undergoes predicate fronting. Maximal predicate phrase fronting is seen in other cases also, for example, in cases of predicate nominals or prepositional predicates, it is an XP predicate which fronts.¹⁶ Massam and Smallwood (1997) and Massam (to appear) argue that this fronting is to specifier of IP (contra Carnie 1995 for Irish, who argues that complex predicates can move to a head position, i.e., to INFL). Examples of nonverbal predicate sentences are shown below.

(11)a. [Ko e tau kamuta] fakamua a lautolu.

Pred Abs Pl carpenter before Abs they

They were carpenters before this.

(S.136b:54)

b. [Hā he fale gagao] a ia.

Pred in house sick Abs she

She is in the hospital.

(S.138a:54)

From examples such as these it is clear that predicate fronting can apply to an XP in Niuean, since in (11a), for example, the entire predicate nominal

¹⁶ This is also shown for Tahitian in Lazard and Peltzer (1991), and see also Freeze (1992). Carnie (1995) discusses this phenomenon in Irish, and Lee (to appear) and Rackowski and Travis (to appear) also argue that predicate fronting applies to maximal projections in a variety of languages. Déchaine (1993) also argues for a uniform view of predicates across categories.

appears to the left of the postverbal modifier *fakamua* 'before' and to the left of the subject (cf. Freeze 1992). PNI is thus simply another instance of XP predicate fronting, like DP fronting in sentences such as (11a) except that $X = V$, not D, in the PNI cases.

In fact, we can view *all* instances of predicate fronting in Niuean as XP fronting. In (1a–d) as well, it is posited that it is the minimal VP (excluding adjoined prepositional arguments) which fronts. Since the object has moved out of the minimal VP to specifier of AbsP, only its trace will undergo predicate fronting, giving the effect of VSO rather than VOS. The predicate fronting rule in Niuean can be summed up as in (12).

- (12)a. The minimal predicate phrase fronts to Spec IP to check a Pred feature in INFL.
- b. The minimal predicate phrase is the head of the predicate phrase plus its complement.

Unification of predicate fronting as movement of a maximal projection is desirable, as it is otherwise difficult to account for why, when the predicate is nominal, it is a maximal projection which fronts, whereas when the predicate is verbal, it would be simply V which fronts. A uniform analysis is possible on the assumption that we can define the minimal VP so as to exclude all adjoined prepositional phrases. This analysis derives the absence of SVO structures in Niuean, since the specifier of IP is filled with the predicate, capturing the claim of Massam and Smallwood (1997) that predicate fronting is the VSO realization of the EPP.

In this view, then, Niuean VSO is in all cases derived by the fronting of the minimal VP, and PNI is the result of generation of an NP (as opposed to DP) object, which fails to move out of the minimal VP, thus fronting along with the verb.

The analysis presupposes the existence of an NP constituent in Niuean which includes the noun and its modifiers, but excludes nominal functional projections and possessors. Such a constituent is plausible, as discussed in section 1, though, admittedly, more work needs to be done on nominal structure in Niuean.

3. THE CHARACTERISTICS OF NIUEAN PNI

In this section, we first discuss the properties of Niuean PNI more or less descriptively, returning below to the issue of how the Niuean facts fit into theoretical analyses of NI in general, and the PNI analysis presented above

in particular. Seiter isolates three types of what he calls NI in Niuean, which I call general PNI, existential PNI, and instrumental PNI. This paper deals mainly with the first two types, although some remarks will be made about instrumental PNI as well.

3.1. Type I: General PNI

General PNI is possible with a large open class of verbs. The variety of possibilities is illustrated in the sampling in (13). This type of NI appears somewhat sparingly in texts, but it is easy to elicit, and it appears to be a robust phenomenon in the language.

(13)	<i>fanogonogo lologo</i>	listen song
	<i>ama kalahimu</i>	hunt crab
	<i>inu kofe</i>	drink coffee
	<i>takafaga ika</i>	catch fish
	<i>tā fakatino</i>	draw picture
	<i>fakaholo motokā</i>	drive car
	<i>kai apala/niu/ika</i>	eat apple/coconut/fish
	<i>holoholo kapiniu</i>	wash dish
	<i>taute motokā</i>	fix car
	<i>manako manu</i>	like animal
	<i>vali fale</i>	paint house
	<i>tō huli talo</i>	plant taro shoot
	<i>volu niu</i>	grate coconut
	<i>fakatali tagata</i>	await people
	<i>tutu hiapo</i>	beat hiapo bark
	<i>kumi mena/tagata</i>	search thing/people
	<i>lagomatai gahua</i>	help=out=with work
	<i>fagai ika</i>	feed fish (e.g., to a cat)
	<i>kana motokā</i>	wash car
	<i>taute mafola</i>	make peace
	<i>fana peka</i>	shoot flying fox
	<i>fagai vine</i>	pollinate flowers

The pseudo incorporated NP may not appear preceded by any functional categories, nor may it appear with a relative clause, whether or not the relative clause is fronted along with the head of the relative, as seen in

(14a–b). (14c–f) show that case markers, number articles, and possessors may not appear with the fronted noun.

- (14)a. *Ne inu kofe a Sione ne taute e au.
Pst drink coffee Abs Sione that made Erg I
 (Sione drank coffee that I made/*Sione coffee-drunk that I made.)
- b. *Ne inu kofe ne taute e au a Sione.
Pst drink coffee Nonfut make Erg I Abs Sione
 (Sione drank coffee that I made.)
- c. *Ne inu e kofe kona a Mele.
Pst drink Abs coffee bitter Abs Mele
 (Mele drank the bitter coffee.)
- d. *Kua holoholo tau kapiniu a Mele.
Perf wash Pl dishes Abs Mele
 (Mele washes the dishes.)
- e. *Ne vali fale ha Mele a Sione.
Pst paint house Gen Mele Abs Sione
 (Sione paints Mele's house.)
- f. *Kua ama taha kalahimu a ia.
Perf hunt one crab Abs he
 (He is hunting one crab.)

Seiter (1980) states that general NI provides a habitual or frequentative meaning. This meaning for NI structures is discussed by Mithun (1984), who ties it to the fact that the incorporated noun in this type of NI is non-specific and non-referential.¹⁷ Judging from the contexts in which it is found, the Niuean general NI incorporated nominal is also non-specific

¹⁷ I define specificity and definiteness in the familiar ways, as developed in Kamp (1981), Heim (1982) and Enç (1991). For Enç (1991), definite DPs are identical in reference to a previously established referent, as opposed to indefinite DPs which are not. Within indefinite DPs, there are specific DPs which are weakly linked to previously established referents, for example, through being a subset of a familiar referent, and non-specific DPs (or NPs), which introduce new entities into the discourse.

(thus indefinite). This is supported by the fact that when a PNI nominal appears with a negative or a modal verb, it takes narrow scope – see (24a) and (27a) – and it is compatible with Enç’s (1991) claim that only non-specific NPs can be in the scope of an existential verb.

We now consider whether Niuean PNI nominals are referential. Let us first clarify this term, following Ghomeshi’s (1996) discussion of referentiality. According to Givón (1978), Rapoport (1987) and Akmajian (1970), a referential nominal is one which has a nonempty reference, i.e., which ‘exists’ in a particular universe of discourse (though not necessarily in the real world). A non-referential nominal, on the other hand, does not introduce a potential discourse referent, but is instead used as a label, referring to type not token. Ghomeshi (1999) further argues that non-referential nominals divide into generics and modifying nominals. It is the latter which is relevant to the discussion of Niuean PNI. Canonically nonreferential nominals of the modifying type are found inside compounds in English such as *truck-driver* and in phrases such as *leather purse* or *stone wall*. The syntax of referentiality is discussed in Higginbotham (1985), where it is proposed that common nouns have an open place allowing them to denote a type. It is only when this open place or variable is bound by a determiner (or perhaps by some other extended nominal element) that the noun has a referential reading.

We must determine, then, whether the Niuean PNI nominal is serving in a purely modificational function, or in a referring function. If the latter, then, once introduced, the nominal is set up as a potential referent for the future discourse and is thus able to antecede a pronoun. Non-referential elements may not antecede pronouns (as is the case for nouns inside English compounds and modifying nominals as in *stone wall*). In case of the Niuean incorporated nominal, at first glance it seems possible for a pronominal clitic to refer back to the nominal, as seen below.¹⁸

- (15)a. ... ke kumi mena; ke nonofo ai; a lautolu.
Sbjnctv seek thing Sbjnctv settle there Abs they
 ... they sought a place to settle. (NAH:ch. 1)

¹⁸ While it is not possible to incorporate a tensed relative clause, as seen above in (14b), we see from (15) that it is possible to incorporate a subjunctive relative with a purposive sense. This suggests that the two relatives are structurally different. Howatt (1998) argues that similar clauses in English, namely infinitival relatives, are not in fact relative clauses at all, but rather complement clauses. This approach would explain the differences between the two clause types with respect to the possibility of incorporation. True relative clauses are above the level of the NP, appearing at or above the functional level (see discussion below in text), whereas subjunctive relatives are within the NP level, appearing as complements to the head noun.

- b. ... ke kumi tagata; ke ta mai **pro**_i mo nonofo e motu.
Sbjnctv seek people Sbjnctv bring for settle Abs island
 ... He sought people to bring to settle the island. (NAH:ch. 1)
- c. Ka e pete ia, kua fā mahani foki nī e tau
But though Dem Perf habitual custom return Emph Abs Pl
 tagata he motu nai, ke foaki [mena fakaalofa]; ke
person of island this Sbjnctv give thing gift Sbjnctv
 fakatautonu **aki**_i e tau atuamotu.
make=right with Abs Pl god-island
 But it was very customary for the people of this island to offer
 gifts as a means of propitiation. (NAH:ch. 3)

In (15a), *mena* ‘thing’ is the antecedent to the locative pronominal *ai*; in (15b), *tagata* ‘person’ is the antecedent to the null pronominal in the subjunctive relative; and in (15c), *mena fakaalofa* ‘gift’ is antecedent to the instrumental clitic *aki*.¹⁹ These examples can be compared with the ungrammatical English sentence in (16) below, which might lead us to conclude that the Niuean nominals are referential as opposed to the English nominal within a compound.

- (16) *I went berry-picking to make jam with.

However, in the cases I have found of seeming discourse referentiality of the PNI nominal, the co-reference is internal to the incorporated nominal, i.e., the pronominal clitic (as well as its antecedent) arguably appears in the incorporation domain, within a subjunctive relative clause. Thus the external discourse referentiality of the incorporated NP as a whole is not established by these examples. In fact, the examples above more closely approximate the ungrammatical English sentence in (17). Note that the English sentence is ungrammatical because a non-lexical nominal is being compounded with the verb. It seems, though, that the degree of ungrammaticality caused by the nominal head acting as an antecedent is weaker in (17) than in (16). This suggests that there is no difference between the English compound nominals and the Niuean PNI nominals, other than the fact that the latter may freely be maximal NPs, and thus, the PNI NP in Niuean, like the compounded N in English, is non-referential.

- (17) *I went berry/ies-to-make-jam-with-picking.

¹⁹ See Chapin (1974) and Massam and Roberge (1997) for analysis of the anaphoric locative/temporal element *ai*. Massam (1998) examines the instrumental clitic *aki*.

I conclude from this apparent limitation on reference, which is echoed in English compounds, that the incorporated nominal as a whole is non-referential. This conclusion seems right, in that the lack of referentiality of the nominal bearing the internal theta role ensures an unbounded or non-delimited reading of the event (cf. Jackendoff 1990; Tenny 1994), providing the habitual or frequentative interpretation for PNI constructions noted by Seiter.

General PNI may apply to objects. There are two types of object in Niuean, case-marked as absolutive and middle respectively (Chung 1978). Verbs with canonically transitive semantics take ergative subjects and absolutive objects, while psychological verbs and some other non-affecting verbs take absolutive subjects and middle objects. Niuean middle case marking is morphologically identical to locative case, but middle arguments behave differently in that they may undergo PNI, whereas locatives may not. A pseudo incorporated middle is shown below in (18b).

(18)a. Ko e fanogonogo a lautolu ke he tau lologo.

Pres listen Abs they to Pl songs

They were listening to songs.

b. Ko e fanogonogo lologo a lautolu.

Pres listen song Abs they

They were listening to songs.

Chung (1978) argues that in various Polynesian languages middle objects are direct objects, but Seiter shows that in Niuean most diagnostics class middle sentences as intransitives. In this paper, we consider a PNI middle object to be generated as sister to the verb if it is generated as a bare NP, which enables it to front along with the verb (18b). Although as an NP it is sister to the verb at D-structure, when it bears middle case morphology it appears as a prepositional object, adjoined to the minimal VP (18a). This explains why it does not act as a direct object when it appears with middle Case morphology.

Seiter states that subjects cannot incorporate, nor can other indirect or oblique elements.

(19)a. *Koli tagata he pō Falaile.

dance person on night Friday

(People dance on Friday night.)

(S.199b:73)

- b. *Fano tapu a ia he aho tapu.
go church Abs he on day Sunday
 (He goes to church on Sundays.) (S.202b:74)

There are some examples of PNI, however, which at first seem to suggest that it might be possible to incorporate the external argument of a verb, given the right context.

- (20) ko e liga ne kamata nonofo tagata a Niue
Pred Abs likely Nfut begin settle people Abs Niue
 ... the likelihood that people begin to settle in Niue [fifteen
 hundred years ago] ... (NAH:ch. 1)

The verb *nonofo* usually takes the agent of 'settle' as its single argument, as seen in (21), taken from Sperlich's (1997) entry for *nonofo* (under *nofu*).

- (21) Kua nonofo a lautolu ki lalo.
Perf sit/stay/dwell Abs they to down
 They sat down. (Sp.242)

Perhaps in (20) 'people' is being used in an instrumental sense, thus falling in with cases to be discussed below. Note that in (20), it is not the case that a single argument has been incorporated, since 'Niue' is an absolutive argument in this sentence. This contrasts with instances of existential PNI, to be discussed below.

In summary, then, the characteristics of general PNI in Niuean are those shown in (22).

- (22) (i) occurs productively with an open class of verbs
 (ii) NP is non-specific and non-referential
 (iii) no extended nominal categories or dependants of extended nominal categories (i.e., tensed relative clauses) appear over N
 (iv) durative/frequentative meaning (Seiter 1980)
 (v) objects (absolutive/middle) incorporate

These characteristics are accounted for in the analysis presented above. The productivity noted in (i) is expected, since any verb with an internal

argument can appear with this argument in NP form rather than DP form. The NP, appearing with no extended projections above it (as noted in (iii)), is necessarily non-referential, hence non-specific and indefinite, as noted in (ii). This lends an unbounded reading to the sentence, thus property (iv) is accounted for. We can account for the fact that relative clause modifiers are disallowed if we follow, for example, Finer (1998), Ghomeshi (1996), Larson (1994), and Kayne (1994), who argue that relative clauses appear high in DPs, at the level of the functional projections which bind the variable position of the NP, rather than appearing as complements of the head noun. Since there are no functional projections above the NP in the PNI construction, there can be no relative clause. Finally, the fact that only objects undergo PNI is accounted for by the fact that in the present analysis, PNI results from the predicate fronting of the minimal VP. Thus, in order to undergo PNI, a nominal must be merged as sister to V^0 .

3.2. Type II: Existential NI with *fai*

Fai incorporation, or existential incorporation, applies to a closed class of verbs, for example *fai* 'have/be' and *muhu* 'have plenty/be plentiful'. Existential NI is very common in texts. Seiter claims that incorporation is obligatory for the verb *fai* 'have/be', but Sperlich (1997) states that *fai* can appear without incorporation, providing the example given in (23) where the verb seems best translated as 'make'.²⁰

- (23) Kua fai nakai e umu haau?
Perf make Ques Abs oven your
 Have you made your oven yet? (Sp.61)

²⁰ *Fai* also occurs without incorporation in the expression denoting immediate future *ha ne fai* 'about to' as seen below (though it is not clear that this is the same *fai*).

- (i) ti manatu nī e tama liga ko e mate ha ne fai a ia
thus think Emph Abs child likely Pred Abs die about=to Abs he
 he keli he matua haana.
because=of beating of father his
 The son thought he was about to die because of his father's beating.

(NAH:ch. 1)

While there are cases of non-incorporating *fai*, Sperlich states that incorporation is obligatory for the verb *muhu*. Two examples appear below.

- (24)a. ... nākai muhu mena mahuiga e falu a
not have=plenty thing sought=after Abs some Abs
 atu-motu Polinesia.
group-island Polynesian
 ... some Polynesian islands don't have a surplus of material
 goods. (NAH:ch. 3)

- b. Kua muhu tala tūmau ha mautolu a tama fifine ka
Perf have=plenty story always Gen our child girl when
 hau he koli.
come from dance
 Our girl had plenty of stories to tell when she came back from
 the dance. (Sp.234)

The PNI nominals here comply with Enç's (1991) characterization of non-specific thus with her claim that existentials occur only with non specific noun phrases. Although existential PNI nominals are non specific, it is clear that they can be referential, in contrast to those above in general PNI. Recall that a referential nominal is one which reiterates or introduces an entity in the discourse and that it contrasts with a purely modificational nominal. The referentiality of the existential PNI nominal is seen by the fact that the incorporated nominal can easily be referred to later in the discourse, as illustrated in (25).

- (25)a. **Fai mena kai a ia ia he fano, ko e fua niu.**²¹
Have thing food Abs she her at go, Pred Abs fruit coconut
 She had food with her when she went: (namely) a coco-
 nut. (NAH:ch. 1)

- b. Ne manatu e Mataginifale ko e mena **fai**
Pst think Abs Mataginifale Pred Abs thing have
mata-fohi haku hiapo a ia ne huhulu **pro** he
blade-scraper scratch tapa-plant Abs she Nfut shove in
 malo felevehi kua aaki mai **pro** e ia ko e
waist-cloth Perf take from=there Abs she Pred Abs
 lapa tofe ti hagaaki volu **aki** e ia e
board mussel then continue scrape with=it Erg she Abs
 manava he ika a ti oti kua lololole e ika mo e nāikai
stomach of fish then all Perf weak Erg fish and not
 fāhia ke kakau.
be=able Sbjnctv swim

Mataginifale remembered that she had the blade of the tapa plant scratcher which she had twisted in her loincloth, so she took it out, the mussel board, then she kept on scraping with it the stomach of the fish so that the fish got all weak and was not able to swim. (NAH:ch. 1)

Another characteristic of existential incorporation, no doubt related to its referentiality, is that the PNI nominal can be modified by a relative clause, as in (26a), although the relative clause is not permitted to front with the nominal. This last fact cannot be seen in (26b) as there is no indication of the end of the incorporation domain, but it can be seen clearly by the ungrammaticality of (26c), where an attempt has been made to incorporate a noun along with its modifying relative clause.

- (26)a. Ne fai fale a Sione ne tā e au.
Pst have house Abs Sione Pst build Abs I
 Sione has a house that I built.

- b. Kae fai tagata kumikumi ne talahau pēhe ...
though be person investigate Nfut tell thus ...
 Though there is one investigator who tells it this way ...
 (NAH:ch. 1)

²¹ I quote this sentence as it appears in *Niue: A History of the Island* (1992). It contains an error, however, brought to my attention by Sifa Ioane. Preceding the second *ia* 'her', there should be a locative preposition and a personal marker, to read *i a ia* 'Loc/Pers/her', or 'with her'. This error is not relevant to the point being made here.

- c. *Ne [fai fale ne tā e au] a Sione.
Pst [have house NFut build Abs I] Abs Sione.
 (Sione has a house that I built.)

As noted above for general PNI, it appears that a subjunctive relative can be incorporated.

- (27)a. ... ka e nākai fai mena ke tipu aki.
because not have thing Sbjnctv open with
 ... because (he) didn't have anything to open (it) with.
 (NAH:ch. 1)
- b. Ne kumi motu ke nonofo ai nī a lautolu.
Pst seek island Sbjnctv settle there just Abs they
 They just looked for a place to live.

With existential PNI, it is possible to incorporate the only argument in the sentence. If this is done, the sentence is translated with 'be', as in (28a) and (28b). If there is another argument in the clause, then the sentence is translated with 'have', as in (28c), a familiar alternation (Freeze 1992). This appears to also be the case with *muhu* 'have plenty/be plentiful'.

- (28)a. Kua hegi fano e ia e hulu ke kitia poke fai uga
Perf swing go Erg he Abs torch Sbjnctv see if be crab
 nakai.
Ques.
 He swung the torch around to see if there were any crabs.
 (Sp.113)
- b. To fai falaoa a pogipogi.
Fut be bread Abs tomorrow
 There will be bread tomorrow.²² (S.209b:76)
- c. Fai kulī a Pulevaka.
have dog Abs Pulevaka
 Pulevaka has a dog/dogs. (S.20:76)

²² In Seiter (1980) *apogipogi* 'tomorrow' is written as one word. I have changed this here in accordance with *The Niue Language Dictionary* (Sperlich 1997). This temporal adjunct noun takes the pronominal/proper case marker.

In conclusion, the characteristics of existential incorporation are as given in (29).

- (29)
- (i) occurs with closed class of verbs *fai* 'have/be', *muhu* 'have plenty/be plentiful'
 - (ii) relative clause can appear, at the right edge of the sentence
 - (iii) NP is referential, non-specific and indefinite
 - (iv) no functional categories appear over N
 - (v) single argument can incorporate

Interestingly, Chung (1988) reports a similar type of incorporation in Chamorro with the existential verbs *gāi* 'have' and *tāi* 'not have', which obligatorily incorporate an NP (or small clause) complement. Similarly, in Inuktitut there are existential verbs which trigger obligatory incorporation (Sadock 1980; Van Geenhoven 1996; Johns 1999).

We have accounted for (29iv), since an object nominal will front with the predicate only if it has no D or case feature, i.e., only if it is NP. The other characteristics are unexpected. Above, in the discussion of general PNI it was maintained that an NP with no extended projections is non-referential and that a relative clause is a dependent of a nominal extended projection and not of NP. Yet in existential PNI, the bare NP is referential and can be modified by a relative clause. These apparent contradictions will be resolved in section 4.3, where I will also account for the other properties in (29).

3.3. Type III: NI with Instrument/Mean of Conveyance Nouns

A third type of incorporation is mentioned by Seiter (1980), that of instruments or means of conveyance nouns, commonly occurring with verbs of motion as in (30b). I have not studied the characteristics of this type in detail and will mention it only briefly here. Its existence is compatible with claims made about incorporation in this paper (see section 4.2). Examples appear in (30).

- (30)a. To kai titipi mo e huki e tautolu e vala povi.
Fut eat knife and Abs fork Erg we Abs piece beef
 We will eat the beef with knife and fork. (S.197:73)

b. Fano motokā a ia ke he taone.

go car Abs he to town

He went to town by car.

(S.191b:71)

Note that instrument incorporation, like the types discussed above, can apply to a phrase, as shown in (30a). It does not have a habitual reading, as Seiter (1980) notes, which is expected, since here it is not the case that the verb's thematically internal argument is losing its referentiality. The characteristics of instrument incorporation are shown in (31).

- (31) (i) no nominal extended projections appear over NP
 (ii) does not have a durative/frequentative meaning
 (Seiter 1980)

4. DEVELOPING THE ANALYSIS

The analysis presented in section 2 captures the main characteristics of Niuean PNI, such as the fact that it involves phrases, not heads, and the fact that NI affects the transitivity of the verb. But several aspects of Niuean NI remain unaddressed. In this section these other aspects of Niuean PNI will be examined.

4.1. *The Postverbal Clitics*

One of the reasons why the Oceanic phenomenon presented in (5) for Niuean has been considered to involve NI is because the incorporated noun appears immediately adjacent to the verb, preceding all postverbal particles (cf. Lee 1975; Mithun 1984; Rehg 1981; Bauer 1997). If these particles are lexically attached suffixes, then NI must be lexical also. In (32) the Niuean particles are presented, with examples following in (33).

(32) Postverbal elements.

MODAL V NP DIR MAN *aki oti ai* ASPADV EMPH PERF Q*Modals: fia* 'desiderative', *fā* 'habitual', *mata* 'look like', *liga* 'likely', *kamata* 'begin', *teitei* 'nearly'*Directionals: mai* 'towards speaker', *atu* 'towards hearer', *age* 'towards 3rd person', *hake* 'up', *hifo* 'down'*Manner Adverbs: lahi* 'very, really', *fakamitaki* 'well', *fakaeneene* 'carefully'*aki* 'instrumental', *oti* 'universal quantifier', *ai* 'locative-temporal'*Aspectual Adverbs: tūmau* 'always', *hololoa* 'frequently', *agaia* 'still', *agataha* 'immediately'*Emphatic Particles: noa* 'only', *foki* 'also', *nī, lā* 'just', *koa* 'indeed'

The incorporated nominal appears to the left of these particles. Many examples can be found elsewhere in this paper; for example, (6b) shows an incorporated noun followed by a manner adverb, (5b) shows an incorporated noun followed by an aspectual adverb, and (5b) also shows an incorporated noun followed by an emphatic particle. Below I complete the examples with a directional particle (33a), with *aki* (33b), *oti* (33c), and *ai* (33d), with a question particle (33e), and with a perfect particle (33f).

(33)a. ... ke tuku liogi atu ke he atua ...

Sbjnctv deliver prayer Dir3 to God

... to deliver a prayer to God ...

(NAH:ch. 3)

b. Kua tā fakatino aki he tama e malala.

Perf draw picture with Erg child Abs charcoal

The child drew pictures with the charcoal.

c. Kia fagai ika oti e tau pusi.

Perf feed fish all Abs Pl cat

Feed fish to all the cats.

d. Ko e pūhalatū ne ama kalahimu ai a lautolu.

Pred Abs road Nfut hunt crabs there Abs they

the road where they hunt crabs

- e. Manako manu nakai a koe?
Like animal Ques Abs you
 Do you like animals?
- f. Kua fā fakahū vakalele tuai he magafaoa e tau tohi.
Perf Habitual send airplane Perf Erg family Abs Pl letter
 The family used to send the letters by airplane. (S.184c:69)

The proper analysis of these items is not apparent.²³ Krupa (1982) considers them to be particles. Zwicky (1985) argues that there is no such thing as a particle, rather, non-word elements must be either affixes or clitics. These particles pose a problem for the view of Niuean PNI in this paper only if they are lexical affixes (since then they cannot be affixed to VP). It can be shown that the particles in (32) are not affixes. First, many can appear after predicate nominals, which are clearly phrasal. In (34) we see the question particle and an aspectual adverb after a predicate nominal.

- (34)a. Ko koe nakai a ia ma Haliua?
Pred you Q Abs that Voc Haliua
 Is that you, Haliua? (S.135b:54)

- b. Ko e tau kāmuta fakamua a lautolu.
Pred Abs Pl carpenter before Abs they
 They were carpenters before this. (S.136b:54)

The second argument that these particles are not lexical affixes is more complex. Note that if the particle closest to the verb is not a lexical affix attached to the verb, then under normal assumptions, none of the particles can be lexical affixes attached to the verb, since they would be to the right of a non-lexically attached particle. This said, I concede that the leftmost class, that of directional morphemes, might indeed be classed as affixal, since it is a closed class of five monosyllabic elements. The next class, however, does not have the properties normally associated with affixes, since it consists of an open class of adverbial elements which can be morphologically complex (e.g., *fakamitaki* 'cause-good'). Now, as observed

²³ One possibility is that each particle heads its own phrase and becomes attached to the V (or the VP) by successive movement of the V/VP through each functional phrase (cf. Rackowski and Travis to appear). Since the particles pose a problem for my view of PNI only if they are lexical affixes, I am interested here only in showing that they are not lexical affixes, rather than in providing an analysis for their characteristics.

in Seiter (1980), the manner adverbs and the directional morphemes may appear in either order. In (35a) and (35b) we see a manner adverb preceding a directional particle, whereas in (35c) and (35d) we see the opposite order exemplified.

(35)a. Fanogonogo mitaki mai, ma kapitiga!
listen well Dir1 Voc friend
 Listen carefully, friend! (S.53b:20)

b. Ne foleni fakaeue atu e tau patō ke he tau laini
Pst march side=to=side Dir2 Abs Pl duck to Pl line
 fakatatai.
even
 The ducks waddled from side to side as they marched in a row.
 (M:265)

c. Ka e tala atu fakatonu nai e au.
but tell Dir2 directly now Erg I
 But I tell you plainly now. (S.54a:20)

d. Vagahau mai fakatekiteki ki a au!
speak Dir1 slowly to Art me
 Speak slowly to me! (S.54b:20)

This means, of course, that the directional particles are not lexical affixes, since they can appear to the right of an element which is not an affix (consistently with Rackowski and Travis, to appear). This shows that the postverbal particles are not lexical affixes, and thus they do not constitute a counterargument to the claim that in PNI constructions, it is the VP consisting at least of a verb and an NP which fronts to derive the predicate-first order that is characteristic of Niuean. Conversely, the appearance of the PNI nominal inside of these particles cannot be used to argue for NI in Niuean, as it has been used (e.g., Seiter 1980).

4.2. *Instrumental Intricacies*

A second issue for further exploration is the fact that it is possible for an instrument to advance to object if the object has been incorporated.²⁴ This is seen in (36).

- (36)a. Kua tā he tama e tau fakatino aki e malala.
Perf draw Erg child Abs Pl picture with Abs charcoal
 The child has been drawing pictures with the charcoal.
 (S.51a:267)

- b. Kua tā fakatino e tama aki e malala.
Perf draw picture Abs child with Abs charcoal
 The child has been drawing pictures with the charcoal.
 (S.51b:267)

- c. Kua tā fakatino he tama e malala.
Perf draw picture Erg child Abs charcoal
 The child has been drawing pictures with the charcoal.
 (S.51c:267)

In (36c), the theme object has undergone PNI, and the instrument has advanced to object, yielding a transitive sentence, as evidenced by the ergative subject and absolutive instrument object. Further evidence that the instrument is indeed an object is presented in Seiter (1980).

The problem is as follows. If the incorporated object is base generated as sister to V and if it remains in this position throughout the derivation,

²⁴ This is generally the case, except for middle incorporation. If a middle object has incorporated, it is not possible for an instrument to advance to object, as Seiter (1980) observes.

- (i) Ne onoono fetu e ia (*e mena nā).
Pst look star Erg he (Abs thing that)
 He saw stars (*with that thing). (S.61a:271)
- (ii) Ne fakaata motu e ia e mena ia.
He view island Erg he Abs thing that
 He viewed islands with that thing. (S.61b:272)

This might be accounted for in the analysis presented here by the fact that a middle verb cannot have an ergative subject, since this subject is not an agent (see note 15). Since the subject checks absolutive case, this case might not be available for the instrument.

as proposed in this paper, then we must ask how it is possible for the instrument, which cannot be a sister to V, to be treated as a direct object.

This apparent puzzle arises only if we make a particular assumption about Niuean objecthood, namely that absolutive case (and the status of object) may be assigned only to the element which is merged as sister to the verb. That this is not the case, consistently with Larson (1988), is made clear by an examination of instrument advancement which does not involve PNI. Two examples are given in (37).

- (37)a. Kua hele aki tuai e ia e titipi e falaoa.
Perf cut with Perf Erg he Abs knife Abs bread
 He has cut the bread with the knife.

- b. Ne ahu aki e ia e akau e tau toa.
Pst slay with Erg he Abs club Abs Pl hero
 He slayed the heroes with a club (Sp.45)

Note that here there are two absolutive arguments and furthermore, Seiter (1980) demonstrates that both absolutive elements exhibit object properties. An analysis of these data, then, would have to allow for objecthood to be attributed to instruments merged in positions other than sister to the verb. This analysis (e.g., Massam 1998) could simply be extended to account for the PNI cases as in (36c). A tree for (36c) is provided below, where the instrument in Specifier of AbsP checks absolutive case and the NP object fronts with the verb.²⁵

²⁵ It is not clear why this is only possible with instruments, and not with any IO. Perhaps it is because only instruments, being connected with agents, are thematically close enough to the verb to be interpreted without a preposition.

(38)

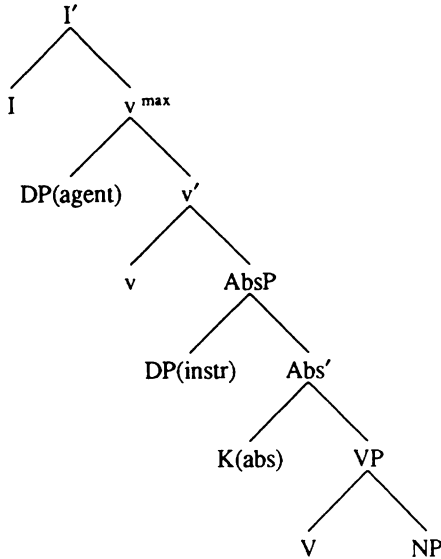

In this section on instruments, let us consider briefly the incorporation of instruments discussed in section 3.3. The analysis of incorporation in this paper would not allow such sentences as (30), where an instrument has been pseudo-incorporated, if the instrument is merged in specifier position of AbsP, as it is in (38), since then the minimal VP would not include the instrument and, hence, the instrument could not front with the verb. But it appears that absolutive instruments and objects can fairly freely exchange places in Niuean sentences, though [Instr/Obj] word order is rare, according to Seiter (1980, p. 286). This is seen in (39), where the instrument follows the patient, compared with (37) where the instrument precedes the patient.

(39)a. Ne haha aki e Sione e kulī e akau.
Pst hit with Erg Sione Abs dog Abs stick
 Sione hit the dog with a stick. (L)

b. Kua fagai aki kia e ia e pusi kehe e tau ika?
Perf feed with Q Erg he Abs cat different Abs Pl fish
 Could he have fed the wrong cat with the fish? (S:287)

If it is possible for an instrument to merge either as sister to the verb or in specifier of AbsP, and conversely, for the patient to merge either in specifier position of AbsP or as sister to the verb, then instrumental incorporation is

explained along with the word order alternation in (37/39) (assuming that absolutive can be checked more than once). Note that there are other cases where an oblique (a locative) appears to be permitted to merge in object position, as exemplified below.

- (40) Kua mohe e ia e timeni.
Perf sleep Erg he Abs floor
 He has slept (on) the floor.

I leave this question somewhat open, pending a more detailed empirical study of instrument incorporation in Niuean.²⁶

4.3. *General vs. Existential PNI*

A third problem which remains unaddressed up to this point is the difference between general PNI and existential PNI. There are three main differences. First, existential PNI can involve a sentence-final relative clause, whereas general PNI cannot. Second, nominals in existential PNI are referential compared to those in general PNI. Third, *fai* PNI can front the single argument, leaving the sentence with no subject.

In order to account for these differences, without losing sight of the similarities between the two types of PNI, I follow the insight of Johns (1999) who considers that the lexical properties of the incorporating verb can be crucial to an explanation of NI phenomena. *Fai* is an existential

²⁶ In fact, I am leaving aside other questions about what elements can appear within the minimal VP. As Whittaker (1982) also notes, there are many instances of postverbal elements which do not fit the description of manner adverb (Smallwood 1998), or incorporated instrument or object. Some examples are given here:

- (i) ... ti liga nī ne pauaki talahu fakagalo pihia
then likely Emph Pst be=deliberate tell lose thus.
 They probably deliberately forgot the story (for this reason) (NAH:ch. 1)
- (ii) Nā ma mea ua tagi, ko e motu kehe a e nai ne
shush oh darling, don't cry, Pred Abs island foreign Emph Abs this Nfu
nonofo paea ai a taua.
 dwell exile there Abs we
 Shush oh darling, don't cry, this is just a foreign land where we live in exile.
 (NAH:ch. 1)

The domain of the minimal VP is clearly a non-argument, modificational domain, but it is not fully clear what may appear within it.

verb. Let us hypothesize, therefore, that it lexically confers referentiality on its internal object i.e., it binds the referential index of the NP in a similar manner to a determiner as developed by Higginbotham (1985). Nichols (1997) and Johns (1999) develop similar ideas to account for Zuni NI and Inuktitut NI, respectively. The non-existential verbs which appear in general PNI do not have this determiner-like binding property. As a result, in these cases the NP object will be non-referential since its referential index is not bound by the incorporating verb, nor by the head of any extended nominal projection, such as DP.

Note that this analysis implies that *fai* is essentially at one and the same time a verb and a determiner, in that it serves simultaneously as the main lexical predicate head for the sentence, and as a functional category which confers referentiality on its complement NP.²⁷ Like Det, *fai* and *muhu* always take an NP complement. If these verbs have the property of binding a variable position in an NP, then PNI will always be obligatory for such verbs, just as most determiners must appear with complements. The idea that elements can simultaneously act as verbs and as nominal functional projections is echoed in Niuean predicate nominals such as (41).

- (41) Ko e kāmuta a au.
Pred Abs carpenter Abs I
 I'm a carpenter.

In predicate nominals as well as PNI constructions with *fai*, the fronted predicate consists of a nominal phrase which follows a quasi-functional verb which also has some properties of a nominal functional projection. In PNI this verb is *fai*; in predicate nominals and equatives it is *ko*. *Ko* has been variously treated as a predicate formative (Seiter 1980; Sperlich 1997) and as a preposition (Clark 1976), thus it has been argued to have verbal and nominal-like properties (as discussed for Hawai'ian 'o in Cook 1999). Like *fai*, it attaches to a nominal phrase (a DP for *ko*, an NP for *fai*), and like *fai* it causes the nominal to become part of the predicate.

As a result of the lexical properties of a verb such as *fai*, its NP complement avoids the usual fate of PNI NPs, i.e., the lack of referentiality. These same properties account for the fact that general PNI (with non-instruments) has a habitual, frequentative meaning, which is not associated with existential PNI. These ideas are reinforced by Van Geenhoven (1996) who, looking at West Greenlandic incorporation, states that incorporating verbs in this language have the property of introducing a new discourse referent.

²⁷ Koskinen (1998) argues that such hybrid categories are the norm, given a featural analysis of category.

It remains to account for the possibility of apparently stranded relative clauses in existential PNI, but not in general PNI. First, note that the analysis of incorporation presented here rules out the possibility that the relative clause is structurally part of the PNI NP at any point in the derivation. This is not a problem, however, since relative clauses can be separate from the nominals they modify, as shown in (42).

- (42) A woman arrived last week who had never been to L'Acadie before.

Various analyses appear in the literature. In some, the relative clause appears at some level of structure in a constituent with the modified element and movement rules separate them, in others the relative clause never appears in a constituent with the modified element. The analysis of Niuean NI presented here would be compatible with analyses of the latter type. For example, we might follow Van Geenhoven (1996) who argues that in West Greenlandic the 'stranded' relative clause is actually base generated separately from the incorporated noun which it modifies.

We have suggested how it is possible for relative clauses to appear in PNI clauses in Niuean, but we have not accounted for why they are impossible with general PNI. Again, the answer has to do with referentiality. Finer (1998), Ghomeshi (1996), Larson (1994), and Kayne (1994), for example, argue that a relative clause appears high in a DP, at the level of the functional projection which binds the variable position of the NP, rather than appearing as a complement of the head noun. This might be related to the fact that a relative clause cannot modify a noun which is itself a modifier, i.e., non-referential nouns. For example, Finer (1998) proposes a structure such as (43) for relative clauses in the Austronesian language Sulawesi.

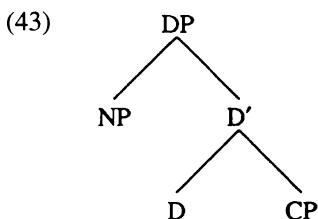

If the incorporated nominal in a *fai* sentence is referential by virtue of *fai* itself, then it will be possible for it to be modified by a relative clause, provided that the relative clause appears at least as high as *fai*, perhaps adjoined to VP (it is thus left behind when predicate fronting occurs).

Nominals in general PNI sentences, however, are non-referential at all levels, hence may not be so modified. On the other hand, if subjunctive relatives as in (15) appear as modifier complements of N (see footnote 18), then these relative clauses can appear as part of a PNI nominal.

A final difference between existential incorporation and general incorporation is that the former can involve the single argument in the sentence, as seen in (28a), for example. If we assume that Niuean is a language where the EPP does not hold of subjects (cf. Massam 2000), then we might predict that this would be possible for general PNI also, at least in case of unaccusative verbs.²⁸ Or, looked at another way, an analysis might predict that such examples would be universally ruled out because of the Niuean predicate's need to assign absolutive case, which, *fai* sentences aside, appears in every Niuean sentence. Even in some examples of general PNI where it appears that an unaccusative 'subject' argument has been incorporated, such as (20) repeated below, there is still an argument *Niue* (locative? patient?) that receives absolutive case.

- (20) ko e liga ne kamata nonofo tagata a Niue
Pred Abs likely Nfut begin settle people Abs Niue
 ... the likelihood that people begin to settle in Niue [fifteen
 hundred years ago] ... (NAH:ch. 1)

A straightforward solution to the problem of why *fai* can incorporate a single argument, whereas other intransitive verbs cannot, is to stipulate that *fai*, as an existential, can optionally not assign/check absolutive case. In this characteristic again it is like the multi-functional predicate particle *ko*, which can appear in a predicate phrase which has no absolutive argument, as shown below where the single argument is itself a *ko* phrase and not an absolutive phrase. We can surmise that this property is tied to the thematically empty nature of the two elements.

- (44) Ko e hāna a nofoaga ko Houma.
Pred Abs his Art dwelling=place Pred Houma
 His dwelling place was Houma. (M.131)

Another solution would be to posit a null expletive in (28a) which receives absolutive case. We leave open which approach is preferable.

We have thus accounted for the morphosyntactic properties of Niuean NI which have been brought to light in this and previous works on the subject.

²⁸ Thanks to Sandra Chung for pointing this out.

5. NIUEAN PNI AND PREVIOUS ANALYSES OF NOUN INCORPORATION

We have seen that Niuean PNI involves a nominal phrase rather than a nominal head. It is mainly for this reason that it cannot be accounted for by analyses presented in the literature since, following standard X-bar theory (e.g., Lightfoot 1979 or Kayne 1994) maximal projections cannot appear in head position. In this section three approaches to NI are briefly outlined, to illustrate that they are indeed designed to account only for incorporation of a nominal head. (45a) schematically illustrates Baker's (1988) syntactic movement analysis, while (45b) shows the same type of analysis with Baker's (1997) assumptions about VP structure. In both, a transitive VP is generated, then the head of the object moves to adjoin to the verb.

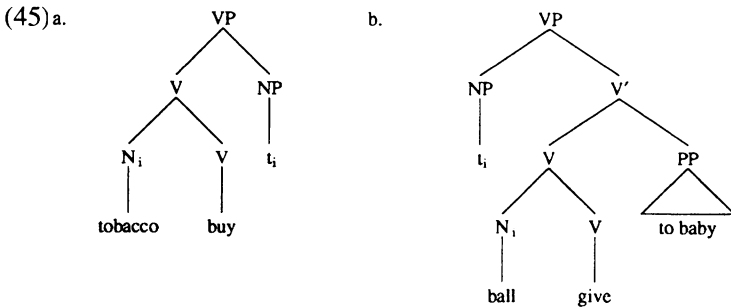

In (46), a schematization of Rosen's (1989) lexical analysis is shown. (46a) represents the type of NI in which the lexical compound is still able to assign its internal theta role, thus a copy or *pro* may appear, whereas (46b) represents the type in which the compounded nominal saturates the thematic role of the verb, rendering the verb intransitive. Rosen considers Niuean to instantiate (46b) since there is no possibility for a copy or for stranded material (with the exception of the extraposed relative clause discussed above).

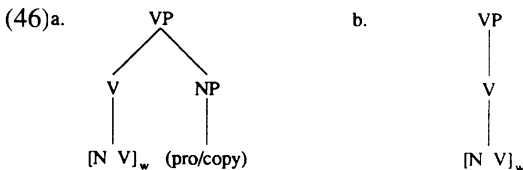

In (47) an X^0 adjunction structure is shown. Here, the structure under V, which in Baker's view arises via movement, is simply base generated.

Ghomeshi and Massam (1994) propose such a structure for Persian complex predicates, which, while behaving like words in some respects, can be split by movement and clitic placement processes.²⁹ Van Geenhoven (1996) presents a detailed analysis of West Greenlandic NI, utilizing what she terms syntactically base generated word formation. Both analyses utilize the notion of X^0 or sub-phrasal syntax.

- (47) X^0 *Juxtaposition* (Ghomeshi and Massam 1994; Van Geenhoven 1996)

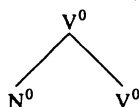

In addition to the analyses above, there is also the parallel structure approach to noun incorporation of Sadock (1980, 1985, 1991). In this view, syntax and morphology each have a separate representation, and the two can differ to a large extent.

As stated above, Niuean NI is not readily accounted for in any of the above analyses, since the first three are designed to account for incorporation of a nominal head, and all four are held to create an X^0 or a morphological word. For example, in the Baker (1997) approach to NI, it is held that syntactic NI occurs only in polysynthetic languages, which exhibit a rich agreement system. The nouns that incorporate parallel the agreement affixes in representing the thematic arguments of the sentence. Any phrasal NPs that may occur in the sentence are adjuncts, outside the polysynthetic word (cf. Jelinek 1984; Marantz 1984; Baker 1988.) Given this, Baker (1997) claims that only polysynthetic languages should exhibit NI with the following four properties: (a) productivity; (b) noun root fully integrated with the verb morphologically; (c) the noun referentially active in the discourse; (d) both the noun root and the verb root able to be used independently. Baker states that Oceanic languages are excluded due to (c), but we saw that this is not always the case. Instead, we have argued Niuean is to be excluded due to (b). At any rate, it is clear that Niuean is not a polysynthetic language. There are no agreement affixes on the verb,³⁰ and little inflectional morphology in general (Krupa 1982). The analysis in this paper does not contradict Baker's view that NI is limited to polysynthetic languages.

²⁹ Ghomeshi (1996) presents a different analysis of Persian complex predicates.

³⁰ Some verbs are lexically specified to agree (by reduplication or suppletion) with their subjects or objects for number (as discussed in Seiter 1980), but this does not constitute a regular agreement system.

Let us consider other characteristics of Niuean PNI in light of the classifications devised by researchers of NI. In fact, as we would predict, it is difficult to classify Niuean NI in these systems. Aside from the fact that Niuean NI appears to involve NPs rather than Ns, there are several other differences.

Of the four criteria given for syntactic NI in Baker (1988), as discussed in di Sciullo and Williams (1987), Niuean meets only two. The four criteria are (a) stranding; (b) copying; (c) ECP satisfaction; and (d) discourse referentiality. Niuean PNI does not involve clear stranding or copying of elements, but it does appear to meet the ECP, in that only elements which can merge as sister to V can undergo PNI. With respect to the last point, it has been seen that with *fai*, Niuean PNI nominals are discourse-referential. But, while Baker considers this to be indicative of syntactic NI, di Sciullo and Williams argue that it is not a diagnostic for a syntactic operation.

The fact that Niuean PNI does not allow doubling or stranding might cause Rosen (1989) to classify it as compounding NI. Note that these facts are also accounted for in the analysis presented here since the entire PNI nominal must front with the predicate. The one exception in Niuean is the possibility of apparent stranding of a relative clause with *fai* incorporation, as seen in (26a,b). Rosen's classification does not easily allow for this type of incorporation, as she allows (in reference to West Greenlandic). For her, the possibility of stranding implies not compounding but 'classifier NI'. But in classifier NI, the verb remains transitive, and doubling should be permitted. Neither of these characteristics appears to hold in Niuean *fai* NI. It thus can be concluded the Niuean PNI does not meet the criteria of lexical compounding account of NI.

One analysis of NI does not necessarily involve an N⁰ as the incorporated element; that provided by Chung (1988) for Chamorro, where she notes that NI can apply to a maximal projection. She presents the following structure for Chamorro incorporation.

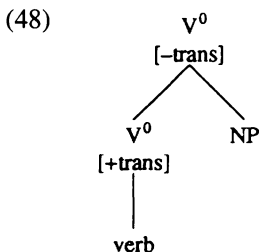

Chung's analysis lies between the X⁰ adjunction analysis and Sadock's mismatch analysis, and might be considered to involve a sort of reanalysis

of NP as N⁰. Although the analysis to be presented here has similarities to Chung's approach, it is not identical, since I take a conservative approach to phrase structure wherein a head is distinct from a phrase (vs. Carnie 1995) and a head cannot contain a phrase (vs. Chung 1988).

Mithun (1984) also classifies NI phenomena. She comes close to admitting Niuean NI, in that she allows for "composition by juxtaposition", that is to say, cases where the V and N "remain separate words phonologically; but as in all compounding, the N loses its syntactic status as an argument of the sentence, and the VN unit functions as an intransitive predicate" (Mithun 1984, p. 849). She considers various Oceanic languages to exhibit this juxtaposition.³¹ This is similar to our view that the verb and nominal remain separate words, and together form the minimal predicate. But for Mithun, "...incorporation is a solidly morphological device that derives lexical items, not sentences" (Mithun, 1984, p. 847). With a constrained theory of phrase structure, Niuean causes problems for this view, given that the incorporated material can be phrasal, as shown above. Mithun does not provide a detailed structural analysis of the incorporation process.

A possible approach to the difficulties of classification of Niuean NI would be to separate general NI and existential NI and to consider the first to be lexical and the second syntactic.³² Existential incorporation seems to exhibit more properties usually associated with syntactic operations, such as possibly some stranding (of relative clauses) and clear referentiality. Given that the two types of incorporation are similar in other ways, though, and given that neither fully meets the criteria of its supposed class, I prefer to maintain a uniform analysis for the two types, and to account for the differences by the properties of the predicates involved as discussed above.

It appears, then, that Niuean PNI is difficult to classify within the systems proposed for NI in the literature. This suggests that an analysis is required for Niuean like the one proposed herein, which is distinct from previous NI analyses.

6. CONCLUSION

Let us consider what Niuean PNI tells us about NI in general. We might consider that it tells us nothing, if we conclude that Niuean PNI is not

³¹ Mithun (1984) calls "composition by juxtaposition" Type I incorporation, in her system of four types. Niuean would in fact properly fit into Mithun's Type II incorporation, since Niuean instruments can advance to object if the direct object is incorporated. Type III for Mithun involves polysynthetic languages, while Type IV is classificatory incorporation.

³² This approach was first suggested to me by Susana Bejar in a course paper on Niuean NI.

in fact NI, since it does not involve the morphological incorporation of an X^0 element into a verb. Alternatively, we might conclude that NI and PNI together constitute a more general grammatical phenomenon which is characterized by the existence in a sentence of a non-referential internal argument: either an N or NP (not DP). A sentence with a non-referential internal argument will of course be one where transitivity features (case, agreement, etc.) are muted (cf. Georgopoulos 1998; Hopper and Thompson 1980; Hale 1998). Another possibility for a non-referential object NP is that it is merged as the argument of an existential verb. In this case, while the nominal is non-referential at the highest nominal level, it becomes referential once its variable is bound by the existential verb, at the level of the VP. The relation between the existential verb and the non-referential NP is analogous to that between a determiner and a non-referential NP, since in both cases the merge serves to bind the open referential variable in the NP (Nichols 1997).

The data presented in this paper show that Niuean PNI cannot be treated by lexical compounding nor head movement. In fact, Niuean PNI does not involve nouns, but rather noun phrases, and it does not involve incorporation, but rather the base generation of a non-referential bare NP which, because it is not a DP, undergoes subsequent predicate fronting along with the verb of the sentence to derive a VOS word order. Niuean thus does not exhibit Noun Incorporation, although the process which it does exhibit, here termed Pseudo Noun Incorporation, shares with Noun Incorporation the properties of involving non-referential objects and reduced transitivity.

REFERENCES

- Akmajian, Adrian. 1970. *Aspects of the Grammar of Focus in English*, unpublished Ph.D. dissertation, MIT.
- Baker, Mark. 1988. *Incorporation: A Theory of Grammatical Function Changing*, University of Chicago Press, Chicago.
- Baker, Mark. 1997. *The Polysynthesis Parameter*, Oxford University Press, Oxford.
- Bauer, Winifred (with William Parker, Te Kareongawai Evans and Te Aroha Noti Teepa). 1997. *The Reed Reference Grammar of Māori*, Reed Books, Auckland.
- Biggs, Bruce. 1974. 'Some Problems of Polynesian Grammar', *Journal of the Polynesian Society* 83, 401–426.
- Bittner, Maria and Ken Hale. 1996. 'The Structural Determination of Case And Agreement', *Linguistic Inquiry* 27, 1–68.
- Black, James and Virginia Motapanyane (eds.). 1997. *Clitics, Checking and Movement*, John Benjamins, Amsterdam.
- Bobaljik, Jonathan. 1993. 'Ergativity and Ergative Unergatives', in Colin Phillips (ed.), *Papers on Case and Agreement II*, MIT Working Papers in Linguistics 19, pp. 45–88.

- Carnie, Andrew. 1995. *Non Verbal Predication and Head Movement*, Ph.D. Dissertation, MIT. Distributed by MIT Working Papers in Linguistics.
- Carnie, Andrew and Eithne Guilfoyle (eds). To appear. *The Syntax of Verb-initial Languages*, Oxford University Press, Oxford.
- Chapin, Paul G. 1974. 'Proto-Polynesian *ai', *Journal of the Polynesian Society* **83**, 259–307.
- Chomsky, Noam. 1995. *The Minimalist Program*, MIT Press, Cambridge, MA.
- Chung, Sandra. 1978. *Case Marking and Grammatical Relations in Polynesian*, University of Texas Press, Austin.
- Chung, Sandra. 1988. 'Incorporation and Small Clauses in Chamorro', unpublished manuscript, University of California, Santa Cruz.
- Clark, Ross. 1976. *Aspects of Proto-Polynesian*, Linguistic Society of New Zealand, Auckland.
- Cole, Shari and Vitolia Kulatea. 1996. *Tau Koloa Fakamotu ha Niue: Tau Koloa Laufa* [Cultural Crafts of Niue: Pandanus Weaving], Government of Niue and Institute of Pacific Studies, Alofi, Niue.
- Cook, Kenneth. 1999. 'Hawai'ian *he*, *'o*, and *i*: Copular Verbs, Prepositions, or Determiners?', *Oceanic Linguistics* **38**, 43–65.
- Di Sciullo, Anna Maria and Edwin Williams. 1987. *On the Definition of Word*, MIT Press, Cambridge, MA.
- Déchaine, Rose-Marie. 1993. *Predicates across Categories*, Ph.D. dissertation, University of Massachusetts at Amherst. Distributed by Graduate Linguistics Student Union.
- Emonds, Joseph. 1980. 'Word Order in Generative Grammar', *Journal of Linguistic Research* **1**, 33–54.
- Enç, Mirvet. 1991. 'The Semantics of Specificity', *Linguistic Inquiry* **22**, 1–26.
- Finer, Dan. 1998. 'V to D Raising in Sulawesi Relatives', in Diane Massam and Barry Miller (eds.), pp. 283–306.
- Freeze, Ray. 1992. 'Existentials and Other Locatives', *Language* **68**, 553–595.
- Georgopoulos, Carol. 1998. 'Direct Object Definiteness Effects', in Diane Massam and Barry Miller (eds.), pp. 307–340.
- Ghomeshi, Jila. 1996. *Projection and Inflection: A Study of Persian Phrase Structure*, Ph.D. dissertation, University of Toronto. Distributed by Toronto Working Papers in Linguistics.
- Ghomeshi, Jila. 1999. 'The Variable Locus of Referentiality in Noun Phrases', paper presented at the Annual meeting of the Canadian Linguistics Association, Université de Sherbrooke.
- Ghomeshi, Jila and Diane Massam. 1994. 'Lexical/Syntactic Relations without Projection', *Linguistic Analysis* **24**, 175–217.
- Giorgi, Alessandra and Giuseppe Longobardi. 1991. *The Syntax of Noun Phrases*, Cambridge University Press, Cambridge.
- Givón, Talmy. 1978. 'Definiteness and Referentiality', in Joseph Greenberg (ed.), *Universals of Human Language* **4**, MIT Press, Cambridge, pp. 291–330.
- Grimshaw, Jane. 1991. 'Extended Projection', unpublished manuscript, Brandeis University and Rutgers University.
- Hale, Mark. 1998. 'Diachronic Aspects of Micronesian Clause Structure', in Diane Massam and Barry Miller (eds.), pp. 341–358.
- Hale, Ken and Samuel Jay Keyser. 1993. 'On Argument Structure and the Lexical Expression of Syntactic Relations', in Ken Hale and Samuel Jay Keyser (eds.), *The View from Building 20*, MIT Press, Cambridge, pp. 53–110.

- Heim, Irene. 1982. *The Semantics of Definite and Indefinite Noun Phrases*, Ph.D. dissertation, University of Massachusetts, Amherst. Distributed by Graduate Linguistics Student Union.
- Higginbotham, James. 1985. 'On Semantics', *Linguistic Inquiry* 16, 547–594.
- Hopper, Paul and Sandra Thompson. 1980. 'Transitivity in Grammar and Discourse', *Language* 56, 251–299.
- Howatt, Mary. 1998. 'Object Infinitival Complements', unpublished M.A. thesis, McGill University.
- Institute of Pacific Studies of the University of the South Pacific and the Government of Niue, Alofi, Niue. 1982. *Niue: A History of the Island*.
- Jackendoff, Ray. 1977. *X-bar Syntax: A Study of Phrase Structure*, MIT Press, Cambridge, MA.
- Jackendoff, Ray. 1990. *Semantic Structures*, MIT Press, Cambridge, MA.
- Jelinek, Eloise. 1984. 'Empty Categories, Case and Non-configurationality', *Natural Language and Linguistic Theory* 2, 39–76.
- Johns, Alana. 1999. 'The Lexical Basis of Noun Incorporation in Inuktitut', paper presented at the Workshop on the Structure and Constituency in the Languages of the Americas, University of British Columbia, March 1999.
- Kamp, Hans. 1981. 'A Theory of Truth and Semantic Representation', in J. Groenendijk, T. Jansen, and M. Stockhof (eds.), *Formal Methods in the Study of Language*, Mathematisch Centrum, Amsterdam, pp. 277–322.
- Kayne, Richard. 1994. *The Antisymmetry of Syntax*, MIT Press, Cambridge, MA.
- Kaulima, Aiao and Clive H. Beaumont. 1994. *A First Book for Learning Niuean*, Clive H. and Daisy J. M. Beaumont, Ranui, Auckland.
- Koskinen, Päivi. 1998. *Features and Categories: Non-finite Constructions in Finnish*, Ph.D. dissertation, University of Toronto. Distributed by Toronto Working Papers in Linguistics.
- Krupa, Viktor. 1982. *Languages of Asia and Africa*. Vol. 4: *The Polynesian Languages*, Routledge and Kegan Paul, London.
- Lane, Chris. 1978. 'Niuean Field Notes', unpublished manuscript, University of Wellington, New Zealand.
- Larson, Richard. 1988. 'On the Double Object Construction', *Linguistic Inquiry* 19, 335–391.
- Larson, Richard. 1994. 'The Projection of DegP and DP Structure', unpublished manuscript, SUNY, Stony brook.
- Lazard, Gilbert and Louise Peltzer. 1991. 'Predicates in Tahitian', *Oceanic Linguistics* 30(1), 1–31.
- Lee, Felicia. To appear. 'Remnant VP Movement and VSO', in Andrew Carnie and Eithne Guilfoyle (eds.).
- Lee, Kee-dong. 1975. *Kusaiean Reference Grammar*, Hawai'i University Press, Honolulu.
- Legate, Julie. 1997. 'Irish Predication: A Minimalist Analysis', unpublished M.A. thesis, University of Toronto.
- Lightfoot, David. 1979. *Principles of Diachronic Syntax*, Cambridge University Press, Cambridge.
- Lynch, John. 1998. *Pacific Languages: An Introduction*, University of Hawai'i Press, Honolulu.
- Marantz, Alex. 1984. *On the Nature of Grammatical Relations*, MIT Press, Cambridge, MA.

- Massam, Diane. 1994. 'Case without Functional Projections', in Päivi Koskinen (ed.), *Proceedings of the 1994 Annual Conference of the Canadian Linguistics Association*, Toronto Working Papers in Linguistics, University of Toronto, pp. 369–380.
- Massam, Diane. 1998. 'Aki and the Nature of Niuean Transitivity', *Oceanic Linguistics* 37(1), 12–28.
- Massam, Diane. 2000. 'Subjects and Predicates in Niuean', in Wolfgang Sperlich and Steven Fischer (eds.), *Leo Pasifika: Proceedings of the Fourth Conference on Oceanic Languages* (Niue Island, July 1999), The Institute of Polyesian Languages and Literatures, New Zealand.
- Massam, Diane. To appear. 'VSO and VOS: Aspects of Niuean Word Order', in Andrew Carnie and Eithne Guilfoyle (eds.).
- Massam, Diane and Barry Miller. 1998. *Arguments and Structure in Austronesian Languages: Thematic Issue of the Canadian Journal of Linguistics* 43(3/4).
- Massam, Diane and Yves Roberge. 1997. 'Operator Bound Clitics and Niuean *ai*', in James Black and Virginia Motapanyane (eds.), pp. 273–299.
- Massam, Diane and Carolyn Smallwood. 1997. 'Essential Features of Predication in English and Niuean', in Kiyomi Kusumoto (ed.), *Proceedings of NELS 27*, Graduate Linguistics Student Union, University of Massachusetts, Amherst, pp. 263–272.
- McEwen, J. M. 1970. *Niue Dictionary*, Department of Māori and Island Affairs, Wellington, New Zealand.
- Mithun, Marianne. 1984. 'The Evolution of Noun Incorporation', *Language* 62, 847–894.
- Nichols, Lynn. 1997. 'DP and Polysynthesis', in K. Kusumoto (ed.), *Proceedings of NELS, 27*, Graduate Linguistics Student Union, University of Massachusetts, Amherst, pp. 305–320.
- Pawley, Andrew. 1966. 'Polynesian Languages: A Subgrouping Based on Shared Innovations in Morphology', *Journal of the Polynesian Society* 75, 39–64.
- Pawley, Andrew. 1967. 'The Relationships of the Polynesian Outlier Languages', *Journal of the Polynesian Society* 76, 259–296.
- Pearce, Elizabeth. 1998. 'The Syntax of Genitives in the Māori DP', in Diane Massam and Barry Miller (eds.), pp. 411–434.
- Rackowski, Andrea and Lisa Travis. To appear. 'V-initial Languages: X or XP Movement and Adverb Placement', in Andrew Carnie and Eithne Guilfoyle (eds.).
- Rapoport, Tova. 1987. *Copular, Nominal and Small Clauses: A Study of Israeli Hebrew*, Ph.D. dissertation, MIT. Distributed by MIT Working Papers in Linguistics.
- Rehg, Kenneth. 1981. *Ponapean Reference Grammar*, University of Hawai'i Press, Honolulu.
- Rex, Lesley, Tongakilo, Togia Viviani, Ahetoa Aue, Hafe Vilitama, Ikipa Togatature, and Tahafa Talagi (eds.). *Everyday Words and Phrases in English and Niuean*, University of the South Pacific, Niue Centre, Alofi, Niue.
- Ritter, Elizabeth. 1992. 'Cross-linguistic Evidence for NumP', *Canadian Journal of Linguistics* 37, 197–218.
- Rosen, Sarah Thomas. 1989. 'Two Types of Noun Incorporation: A Lexical Analysis', *Language* 65(2), 294–317.
- Sadock, Jerrold. 1980. 'Noun Incorporation in Greenlandic Eskimo: A Case of Syntactic Word Formation', *Language* 56, 300–319.
- Sadock, Jerrold. 1985. 'Autolexical Syntax: A Proposal for the Treatment of Noun Incorporation and Similar Phenomena', *NLLT* 3(4), 379–439.
- Sadock, Jerrold. 1991. *Autolexical Syntax*, The University of Chicago Press, Chicago.
- Seiter, William. 1980. *Studies in Niuean Syntax*, Garland Press, New York.

- Smallwood, Carolyn. 1998. 'Secondary Predicate Incorporation: Licensing Manner in Nahuatl', in C. Grimm, E. Ng and J. Olenn (eds.), *Buffalo Working Papers in Linguistics 98-01*, SUNY, Buffalo, pp. 85–97.
- Sperlich, Wolfgang. 1994. 'A Theory of Verb Classes and Case Morphology in Niuean', paper presented at the Seventh International Conference on Austronesian Languages, University of Leiden, Holland.
- Sperlich, Wolfgang (ed.). 1997. *Tohi Vagahau Niue: Niue Language Dictionary*, University of Hawai'i Press, Honolulu.
- Sproat, Richard. 1985. 'Welsh Syntax and VSO Structure', *Natural Language and Linguistic Theory* 3, 173–216.
- Tenny, Carol. 1994. *Aspectual Roles and the Syntax-semantics Interface*, Kluwer Academic Publishers, Dordrecht.
- Travis, Lisa. 1988. 'The Syntax of Adverbs', in Denise Fekete and Zofia Laubitz (eds.), *McGill Working Papers In Linguistics: Special Issue on Comparative Germanic Syntax*, McGill University, Montreal, pp. 280–310.
- Ura, Hiroyuki. 1998. 'Ergativity and Checking Theory', unpublished manuscript, Osaka University, Japan.
- Van Geenhoven, Veerle. 1996. *Semantic Incorporation and Indefinite Descriptions: Semantic and Syntactic Aspects of Noun Incorporation in West Greenlandic*, unpublished Ph.D. dissertation, Tubingen University.
- Whittaker, Graeme. 1982. *The Niuean Language: An Elementary Grammar and Basic Vocabulary*, University of the South Pacific, Niue Centre, Alofi, Niue.
- Woolford, Ellen. 1997. 'Four-way Case Systems: Ergative, Nominative, Objective and Accusative', *Natural Language and Linguistic Theory* 15, 181–227.
- Zwicky, Arnold M. 1985. 'Clitics and Particles', *Language* 61, 283–305.

Received 14 July 1998

Revised 21 March 2000

Diane Massam
Department of Linguistics
University of Toronto
Toronto, Ontario
M5S 3H1, Canada
dmassam@chass.utoronto.ca